

Issued by Canon (UK) Limited

Model:

iR C6800C
iR C6800CN

Ref No.:

iRC6800-009
(F2-T01-0M3-10025-01)

Date:

30-07-04

Location:

DEVELOPING ASSEMBLY(M/C/Y)

Subject:

Replacing color developing assembly or starter

Detail:

When mounting the color developing assembly to the machine upon replacement of the color developing assembly or starter, be sure to verify that the 4 hooks [1] of the developing assembly are firmly engaged with the 4 mounting holes [2] on the lid of the developing container. (See P-2.)

If the color developing assembly is mounted to the machine as the lid of the developing container is lifted, (See P-1.) it may cause fogged image or toner scattering inside the machine.

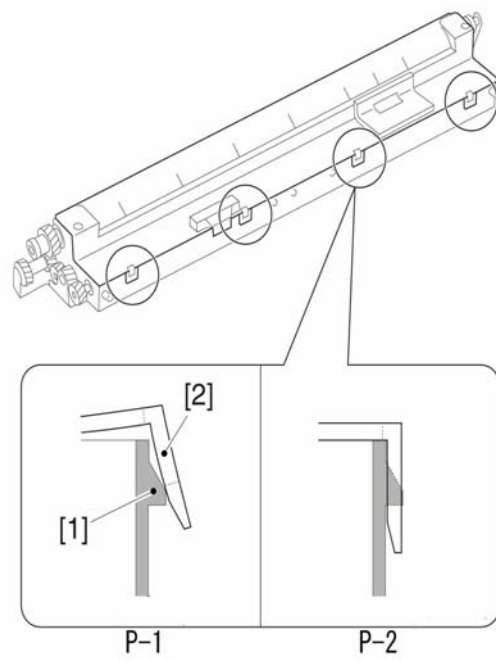

F-1

P-1: The lid of the developing container is lifted and is not secured.

P-2: The hooks of the developing assembly are correctly engaged with the mounting holes on the lid of the developing container.

[1] Hook of the developing assembly

[2] Mounting hole on the lid of the developing container